



AKAI

DVD HOME THEATER SYSTEM

Model:
DV-R4070VSMK

SERVICE MANUAL

MR89EM6-11.1

MT1389E DVD Demo Board for SONY 313/310 PUH

- 1 INDEX & POWER, RESET
- 2 SERVO / MPEG - MT1389E
- 3 MEMORY - SDRAM, FLASH/EEPROM
- 4 AUDIO / VIDEO FILTER

NAME	TYPE	DEVICE
VCC	Digital 5V	SUPPLY
DV33	Digital 3.3V	MT1389E
RFV33	Servo 3.3V	MT1389E
LDO_AV33	Laser Diode 3.3V	
AVCC	RF 5V	PICKUP HEADER
V18	Digital 1.8V	MT1389E
SD33	Digital 3.3V	SDRAM
+12V	Audio +12V	OP AMP.
-12V	Audio -12V	OP AMP.
AVDD	Audio 5V	Audio DAC
DVDD	Audio 5V	Audio DAC

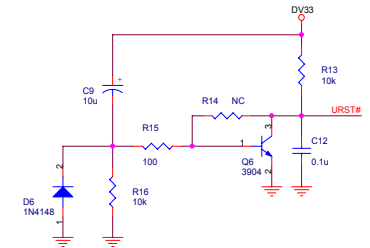
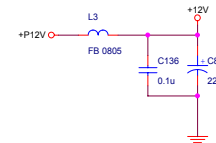
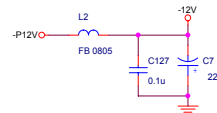
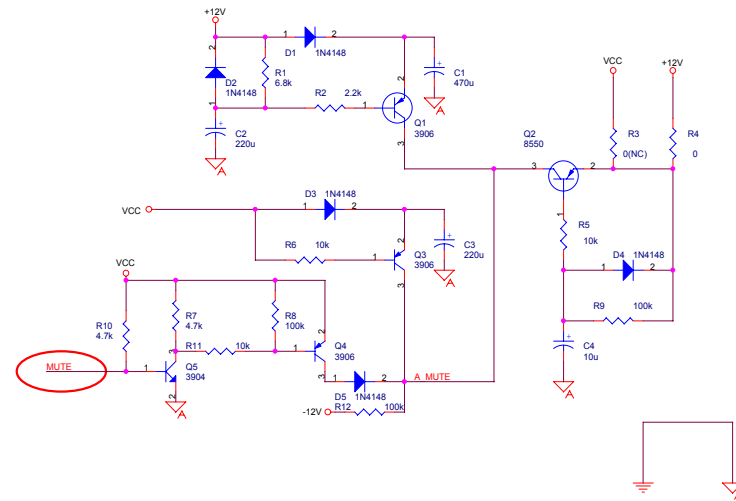

- MUTE >>> MUTE
- A_MUTE >>> A_MUTE
- URST# >>> URST#
- V18 >>> V18
- DV33 >>> DV33
- VCC >>> VCC
- AVCC >>> AVCC
- LDO_AV33 >>> LDO_AV33
- RFV33 >>> RFV33
- +5V >>> +5V
- +12V >>> +12V
- 12V >>> -12V
- MO_VCC >>> MO_VCC
- GND >>> GND

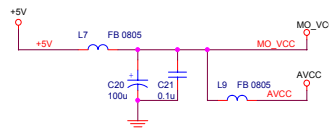
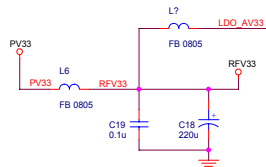
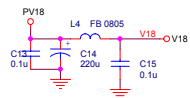
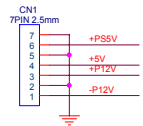

AKAI DV-R4070VSMK		MT1389E RECEIVER 5.1CH OUTPUT	
		File	INDEX
Size	Document Number	Rev	Code
C	RDoc>		<Rev Code>
Date:	Wednesday, March 01, 2006	Sheet	0 of 5

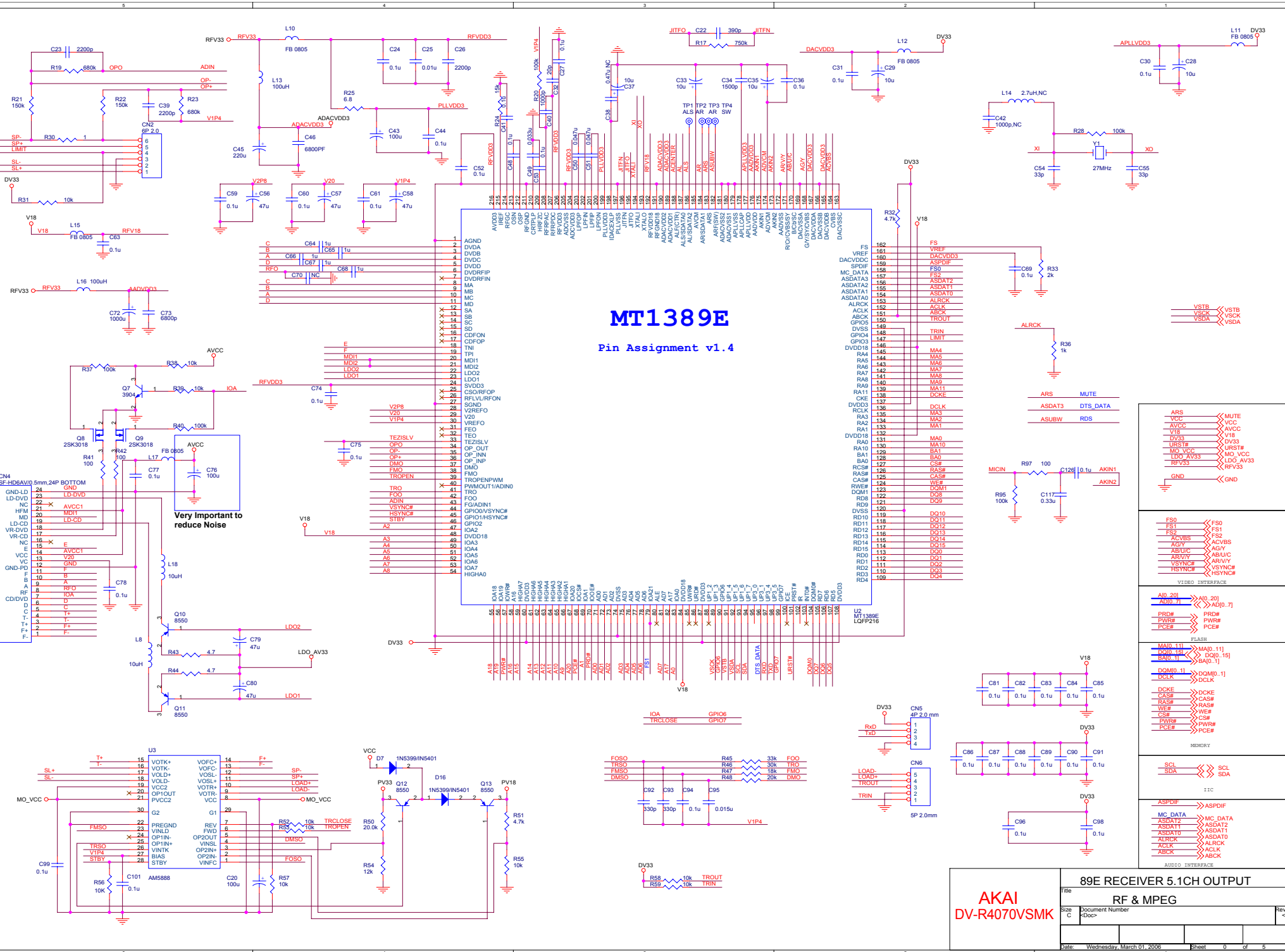

MT1389E

Pin Assignment v1.4

Very Important to reduce Noise

ARS	MUTE
AVCC	VCC
AVCC	AVCC
V18	URS#
DV33	URS#
MO_VCC	MO_VCC
LD0_AV33	LD0_AV33
RFV33	RFV33
GND	GND

FS0	FS0
FS1	FS1
FS2	FS2
ACVBS	ACVBS
AGY	ACVBS
ASUIC	ACVBS
ARVUY	ARVUY
YSNC#	YSNC#
HSYNC#	HSYNC#

A0_20	A0_20
AD0_7	AD0_7
PRD#	PRD#
PWR#	PWR#
PCE#	PCE#

MA0_11	MA0_11
MA0_11	MA0_11
MA0_11	MA0_11
MA0_11	MA0_11
MA0_11	MA0_11
MA0_11	MA0_11
MA0_11	MA0_11
MA0_11	MA0_11
MA0_11	MA0_11
MA0_11	MA0_11

SCL	SCL
SDA	SDA

ASPDI#	ASPDI#
MC_DATA	MC_DATA
ASDAT2	ASDAT2
ASDAT1	ASDAT1
ASDAT0	ASDAT0
ALCK	ALCK
ALCK	ALCK
ABCK	ABCK

AKAI
DV-R4070VSMK

89E RECEIVER 5.1CH OUTPUT

RF & MPEG

Rev <Rev Code>

Date: Wednesday, March 01, 2006 Sheet 0 of 5

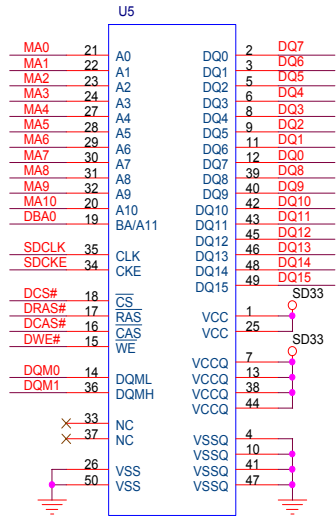

ESMT M12L16161A-7

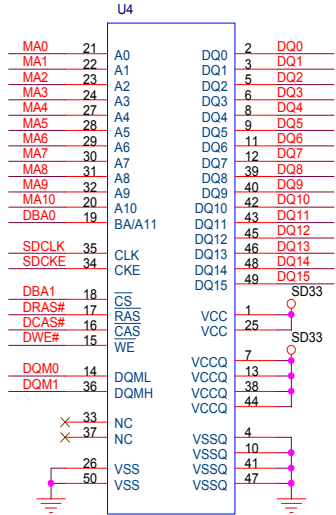

ESMT M12L16161A-7 NC

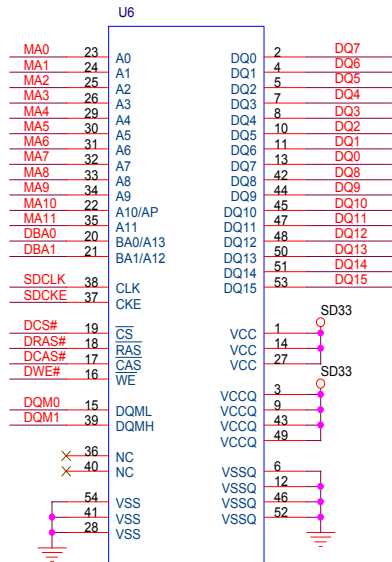
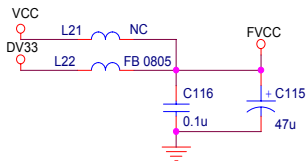

ESMT M12L64164A-7 TSOP54

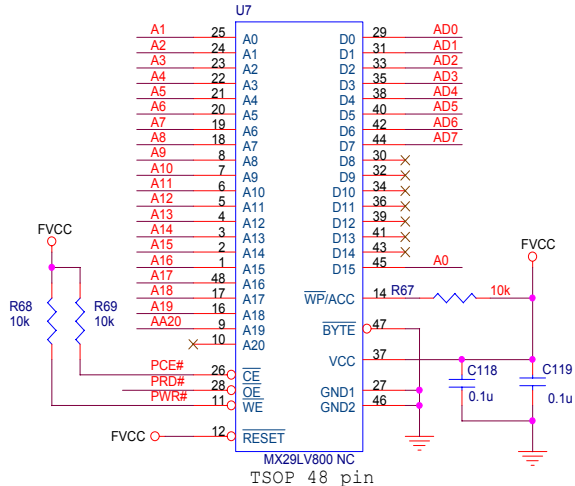

MX29LV800 NC TSOP 48 pin

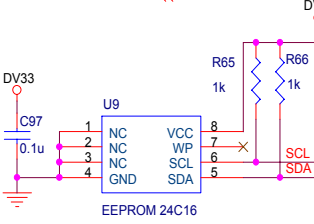
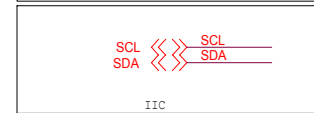
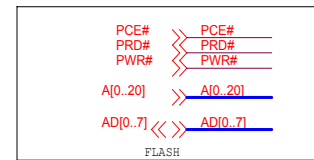
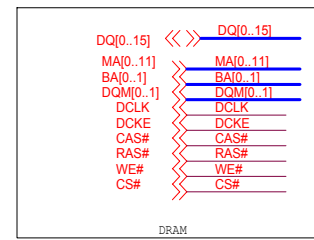
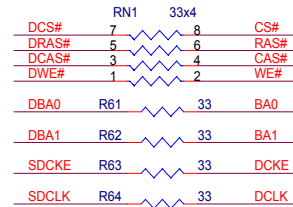
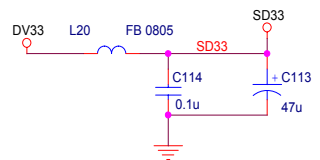
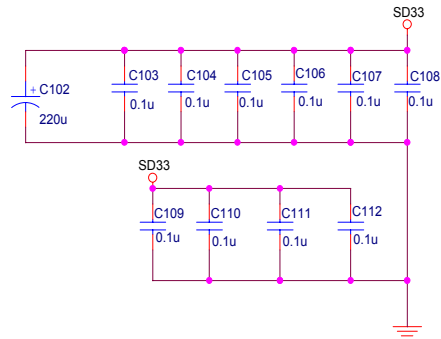

AKAI	DV-R4070VSMK	
	COMMON89D_KHM310_V3	
Size B	Document Number	Rev 1.0
Date:	Wednesday, March 01, 2006	Sheet 0 of 5

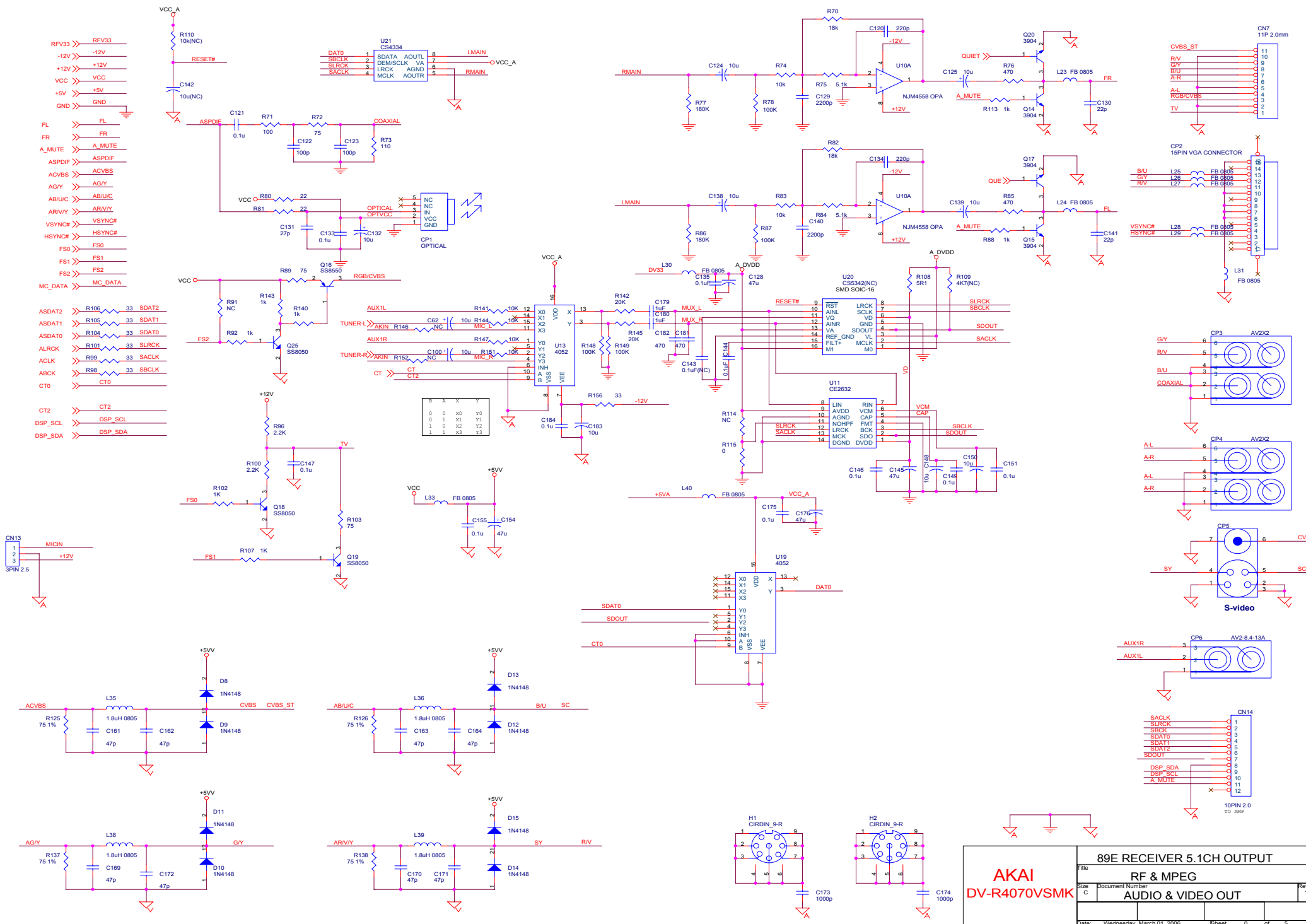

AKAI
DV-R4070VSMK

89E RECEIVER 5.1CH OUTPUT		
RF & MPEG		
File	Document Number	Rev
AUDIO & VIDEO OUT		1.0
Date: Wednesday, March 01, 2006	Sheet	0 of 5

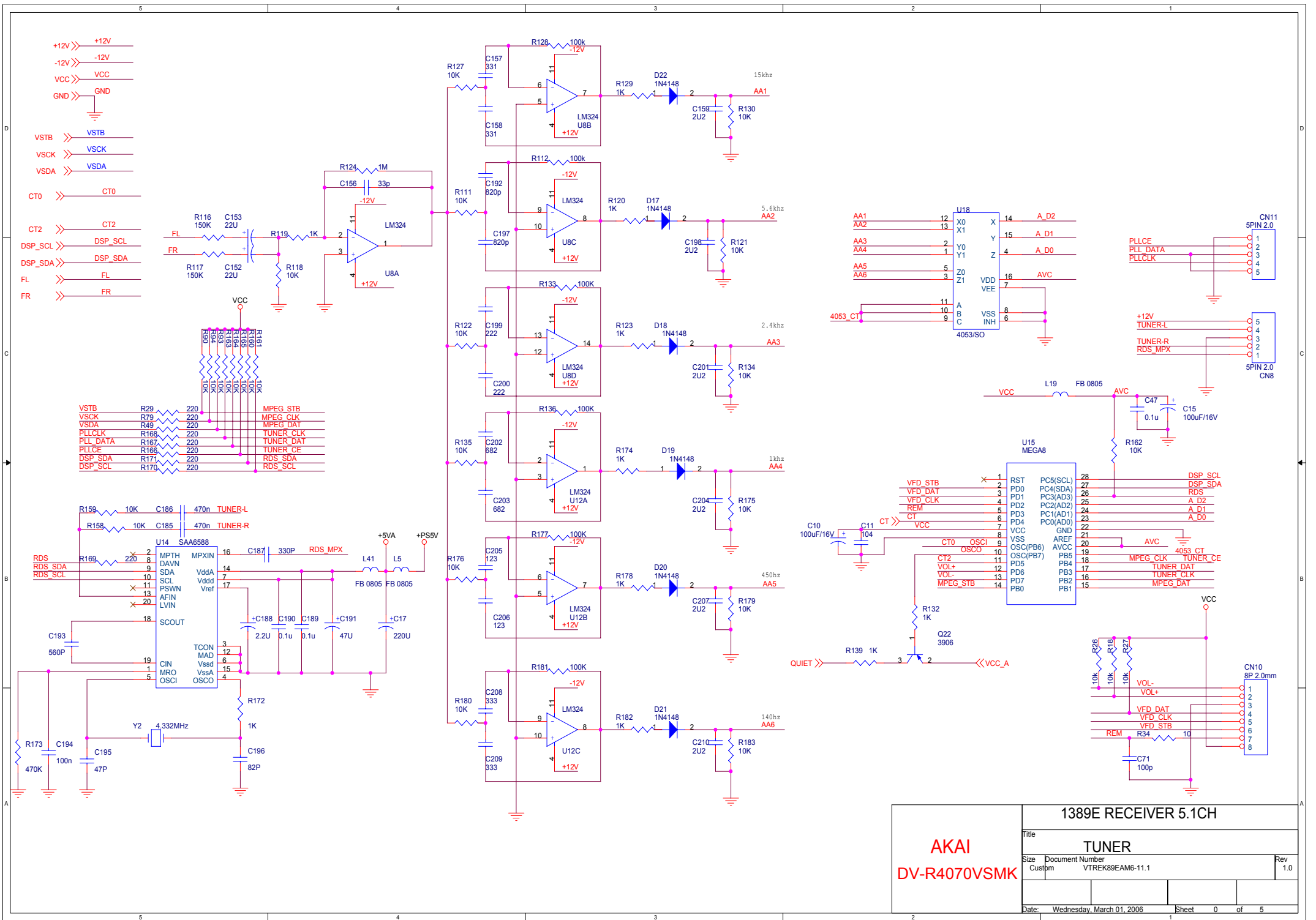

1389E RECEIVER 5.1CH

AKAI
DV-R4070VSMK

TUNER

Size Document Number
Custom VTRK89EAM6-11.1

Date: Wednesday, March 01, 2006 Sheet 0 of 5

